

HH88

GEORGIAN LARGE ENRICHED COVE

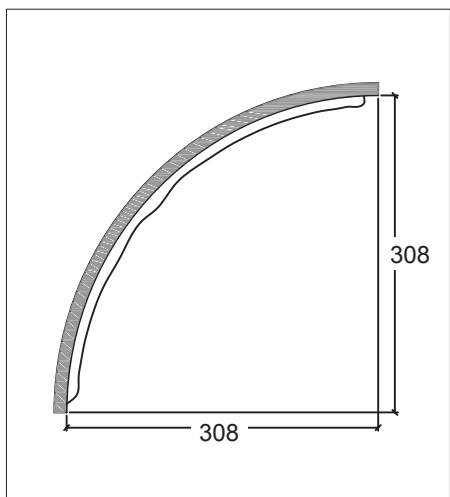
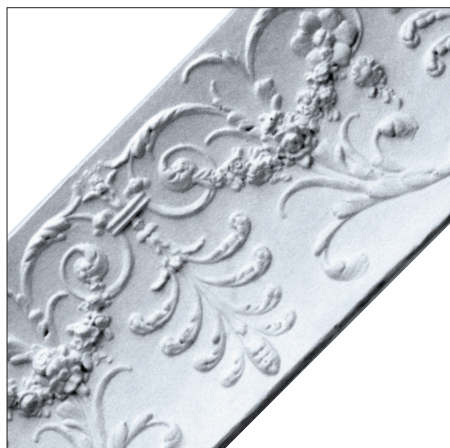

COMPOSITION

Fine Casting plaster is basically Calcium Sulphate hemi-hydrate, with the formula $\text{CaSO}_4 \cdot \frac{1}{2}\text{H}_2\text{O}$

HAZARD IDENTIFICATION

On available data Fine Casting Plaster may on long term exposure to respirable mineral dust cause respiratory problems. May cause dryness to the skin.

FIRST AID MEASURES

Skin contact

Wash with soap and water.

Eye contact

Wash with water for several minutes. Seek medical advice if irritation continues.

Ingestion

No treatment necessary.

Inhalation

Remove to fresh air.

ACCIDENTAL RELEASE MEASURES

Spillage should not be washed into any drain where it may set and cause blockage. Avoid creating dust. Collect by vacuum cleaning.

HANDLING AND STORAGE

7.1 Handling

Use appropriate engineering controls to avoid creating dust. Sacks should be opened in ventilated surroundings.

7.2 Storage

Store in a dry covered area.

DISPOSAL INFORMATION

Fine Casting Plaster is not classified as hazardous waste. Existing EEC, National and Local Regulations must always be complied with.

EXPOSURE CONTROLS & PERSONAL PROTECTION

8.1 Exposure controls

Local exhaust ventilation may be required in circumstances where there is a risk of the product dust.

8.2 Personal protection

Respiratory - Avoid inhaling dust
Hand - Gloves, if risk of skin contact
Eye - Provide eyewash
Skin - Only required for those with sensitive skin

TOXICOLOGICAL INFORMATION

Long term experience of handling this class of product under industrial conditions indicates the absence of any chronic or acute effects.

REGULATORY INFORMATION

EEC Hazard Classification: None.
Maximum exposure limit (8 hours TLA reference period) is 10 mg/m³ total inhalable and 5mg/m³ total respirable dust

SAFETY INFORMATION



The product is non-hazardous and non-flammable

OTHER INFORMATION

The information contained in this Safety Data Sheet is based on the present state of our knowledge. This data is intended to enable safety assessments to be made and should not be construed as guaranteeing specific properties. Users are recommended to consult technical information sheets for specific applications.

HAYLES & HOWE

Hayles & Howe Limited
Templegate, Mead Rise,
Bristol
BS3 4RP

Tel +44 (0)117 972 7200
Fax +44 (0)117 971 2232

email: info@haylesandhowe.co.uk